

# HIGH VOLTAGE COPPER TERMINALS

## CA-M 2A-M

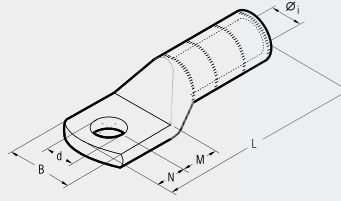

Series CA-M and 2A-M terminals are designed for high voltage applications up to 33 kV.

They are manufactured from high purity copper tube, annealed and tin plated.

The extended barrel enhances both electrical and mechanical performance.

The absence of an inspection hole prevents moisture entry into the crimped joint and makes these terminals suitable for outdoor applications.

Conductor Size (sqmm) & Format	Ø Stud mm	Ref.	Dimensions mm						Quantity Box/Bag	Hydraulic Tools
			Øi	B	M	N	L	d		
25 R/BR/BS*	8	CA 25-M 8	6,8	14,0	9	8	65,0	8,4	300/50	B35-50
	10	CA 25-M 10	6,8	18,0	13	11	72,0	10,5	200/50	
	12	CA 25-M 12	6,8	21,0	16	14	78,0	13,2	200/50	
30 RC/S ÷ 40 S	12	CA 40 S-M 12	8,2	21,0	16	14	79,0	13,2	150/50	
	16	CA 40 S-M 16	8,2	26,0	19	17	85,0	17,0	100/50	
35 BR/BS*	10	CA 35-M 10	8,25	21,0	13	11	73,0	10,5	150/50	
	12	CA 35-M 12	8,25	21,0	16	14	79,0	13,2	150/50	
	16	CA 35-M 16	8,25	26,0	19	17	85,0	17,0	150/50	
50 RC	12	CA 50 R-M 12	8,7	20,5	16	14	79,0	13,2	150/50	
50 S	12	CA 50 S-M 12	9,5	21,0	16	14	79,0	13,2	150/50	
	16	CA 50 S-M 16	9,5	26,0	19	17	85,0	17,0	100/50	
50 BR/BS*	10	CA 50-M 10	9,5	21,0	13	11	73,0	10,5	150/50	
	12	CA 50-M 12	9,5	21,0	16	14	79,0	13,2	150/50	
	14	CA 50-M 14	9,5	25,0	18	16	83,0	15,0	100/50	
63 S ÷ 70 S	16	CA 50-M 16	9,5	26,0	19	17	85,0	17,0	100/50	
	12	CA 70 S-M 12	11,0	28,0	16	14	81,2	13,2	50/25	
70 BR/BS*	16	CA 70 S-M 16	11,0	30,0	19	17	87,2	17,0	50/25	
	10	CA 70 S-M 10	11,0	26,0	13	11	75,2	10,5	50/25	
	12	CA 70 S-M 12	11,0	28,0	16	14	81,2	13,2	50/25	
80 S ÷ 95 RC	14	CA 70 S-M 14	11,0	28,0	18	16	85,2	15,0	50/25	
	16	CA 70 S-M 16	11,0	30,0	19	17	87,2	17,0	50/25	
	12	CA 95 R-M 12	12,0	28,0	16	14	91,0	13,2	50/25	
95 S ÷ 100 S	14	CA 95 R-M 14	12,0	29,0	18	16	95,0	15,0	50/25	
	12	CA 95 S-M 12	13,5	28,0	16	14	91,0	13,2	50/25	
	16	CA 95 S-M 16	13,5	29,0	18	16	94,5	15,0	50/25	
95 BR/BS*	16	CA 95 S-M 16	13,5	30,0	20	17	97,0	17,0	50/25	
	10	CA 95-M 10	13,5	28,0	13	11	85,0	10,5	50/25	
	12	CA 95-M 12	13,5	28,0	16	14	91,0	13,2	50/25	
120 RC/S ÷ 150 RC	16	CA 95-M 16	13,5	30,0	20	17	97,0	17,0	50/25	
	12	CA 150 R-M 12	15,0	31,0	16	14	97,0	13,2	30/15	
	14	CA 150 R-M 14	15,0	31,0	18	16	101,0	15,0	30/15	
120 BR/BS*	12	CA 120-M 12	15,0	31,0	16	14	97,0	13,2	30/15	
	16	CA 120-M 16	15,0	31,0	19	17	103,0	17,0	30/15	
	12	CA 150 S-M 12	16,5	32,0	16	14	97,0	13,2	30/15	
150 S ÷ 160 RC	14	CA 150 S-M 14	16,5	32,0	18	16	101,0	15,0	30/15	
	12	CA 150-M 12	16,5	32,0	16	14	97,0	13,2	30/15	
150 BR/BS*	16	CA 150-M 16	16,5	32,0	19	17	103,0	17,0	30/15	
	14	CA 200 R-M 14	17,0	32,5	18	16	101,0	15,0	30/15	
160 S ÷ 200 RC	12	CA 185-M 12	18,0	33,5	16	14	97,0	13,2	30/15	
185 BR/BS*	16	CA 185-M 16	18,0	33,5	19	17	103,0	17,0	30/15	
	14	CA 240 R-M 14	19,2	43,0	18	16	107,0	15,0	15/5	
200 S ÷ 240 RC	12	CA 315 R-M 12	21,5	43,0	18	16	105,0	15,0	15/5	
240 S ÷ 315 RC	12	CA 240-M 12	20,5	42,0	16	14	103,0	13,2	15/5	
	16	CA 240-M 16	20,5	42,0	19	17	109,0	17,0	15/5	
240 BR/BS*	20	CA 240-M 20	20,5	42,0	22	20	115,0	21,0	15/5	
	12	CA 300-M 12	23,0	43,5	16	14	109,5	13,2	15/5	
	16	CA 300-M 16	23,0	43,5	19	17	115,5	17,0	15/5	
300 BR/BS*	20	CA 300-M 20	23,0	43,5	22	20	121,5	21,0	15/5	
	14	CA 315 S-M 14	23,7	44,0	18	16	105,0	15,0	15/5	
315 S	14	2 A 80-M 14	27,0	51,0	22	19	140,0	15,0	15/5	
	16	2 A 80-M 16	27,0	51,0	22	19	140,0	17,0	15/5	
400 R	20	2 A 80-M 20	27,0	51,0	24	23	146,0	21,0	15/5	
	16	2 A 100-M 16	30,3	56,5	22	19	147,0	17,0	10/5	
500 R	20	2 A 100-M 20	30,3	56,5	24	23	153,0	21,0	10/5	
	16	2 A 120-M 16	33,4	61,5	22	19	159,0	17,0	20/5	
600 R ÷ 630 R	20	2 A 120-M 20	33,4	61,5	24	23	165,0	21,0	20/5	

Conductor Format: R = Round, RC = Round Compact, S = Sector, BR = IEC228 (BS6360) Round, BS\* = IEC228 (BS6360) Sector  
\* = Pre-rounding required, consult Cembre for appropriate die set

# HIGH VOLTAGE TERMINALS

two hole fixing

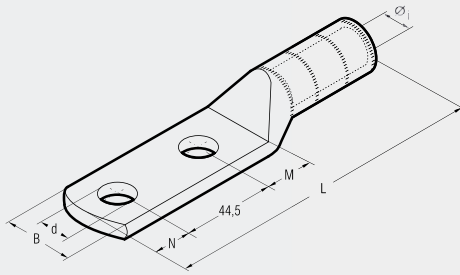

## CA-2M 2A-2M

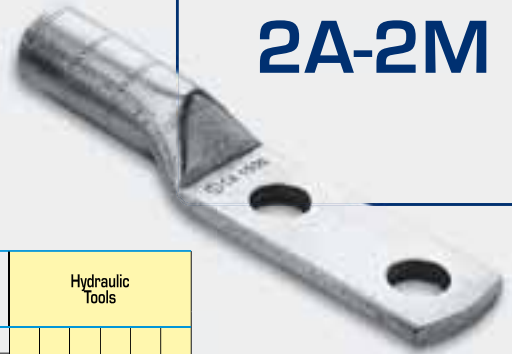

Conductor Size (sqmm) & Format	Ø Stud mm	Ref.	Dimensions mm					Quantity Box/Bag	Hydraulic Tools	
			Øi	B	M	N	L			d
25 R	8	CA 25-2 M 8	6,8	14,0	10	11	113,5	8,4	200/50	B35-50 B 55 RHU 81 HT 81-U HT 120 and tools and heads with 130 kN crimping force ECW-H3D RHU 520
	12	CA 25-2 M 12	6,8	21,0	16	14	122,5	13,2	150/50	
25 BR/BS*	8	CA 25-2 M 8	6,8	14,0	10	11	113,5	8,4	200/50	
	10	CA 25-2 M 10	6,8	18,0	13	11	116,5	10,5	150/50	
	12	CA 25-2 M 12	6,8	21,0	16	14	122,5	13,2	150/50	
30 RC/S ÷ 40 S	12	CA 40 S-2 M 12	8,2	21,5	16	14	123,5	13,2	100/50	
35 BR/BS*	12	CA 35-2 M 12	8,25	21,5	16	14	123,5	13,2	100/50	
50 RC	12	CA 50 R-2 M 12	8,7	20,5	16	14	123,5	13,2	100/50	
50 S	12	CA 50 S-2 M 12	9,5	21,0	16	14	123,5	13,2	100/50	
50 BR/BS*	12	CA 50-2 M 12	9,5	21,0	16	14	123,5	13,2	100/50	
63 S ÷ 70 S	12	CA 70 S-2 M 12	11,0	27,0	16	14	127,7	13,2	50/25	
70 BR/BS*	12	CA 70 S-2 M 12	11,0	27,0	16	14	127,7	13,2	50/25	
80 S ÷ 95 RC	14	CA 95 R-2 M 14	12,0	28,0	18	16	139,5	15,0	30/15	
95 S ÷ 100 S	14	CA 95 S-2 M 14	13,5	29,0	18	16	139,5	15,0	30/15	
95 BR/BS*	12	CA 95-2 M 12	13,5	28,0	16	14	135,5	13,2	30/15	
120 RC/S ÷ 150 RC	14	CA 150 R-2 M 14	15,0	31,0	18	16	145,5	15,0	30/15	
120 BR/BS*	12	CA 120-2 M 12	15,0	31,0	16	14	141,5	13,2	30/15	
150 S ÷ 160 RC	14	CA 150 S-2 M 14	16,5	32,0	18	16	145,5	15,0	30/15	
150 BR/BS*	12	CA 150-2 M 12	16,5	32,0	16	14	141,5	13,2	30/15	
160 S ÷ 200 RC	14	CA 200 R-2 M 14	17,0	32,5	18	16	145,0	15,0	30/15	
185 BR/BS*	12	CA 185-2 M 12	18,0	32,5	16	14	141,5	13,2	30/15	
200 S ÷ 240 RC	14	CA 240 R-2 M 14	19,2	43,0	18	16	151,5	15,0	15/5	
240 S ÷ 315 RC	14	CA 315 R-2 M 14	21,5	43,0	18	16	149,5	15,0	20/5	
240 BR/BS*	12	CA 240-2 M 12	20,5	43,0	16	14	147,5	13,2	15/5	
300 BR/BS*	12	CA 300-2 M 12	23,0	43,0	16	14	145,5	13,2	20/5	
315 S	14	CA 315 S-2 M 14	23,7	44,0	18	16	149,5	15,0	20/5	
400 R	12	2 A 80-2 M 12	27,0	51,0	20	14	177,5	13,2	15/5	
	14	2 A 80-2 M 14	27,0	51,0	22	16	181,5	15,0	15/5	
	16	2 A 80-2 M 16	27,0	51,0	22	19	184,5	17,0	15/5	
500 R	14	2 A 100-2 M 14	30,3	56,5	22	16	182,5	15,0	10/5	
	16	2 A 100-2 M 16	30,3	56,5	22	19	185,5	17,0	10/5	
600 R ÷ 630 R	14	2 A 120-2 M 14	33,4	61,5	22	16	200,5	15,0	15/5	
	16	2 A 120-2 M 16	33,4	61,5	22	19	202,5	17,0	15/5	

Conductor Format: R = Round, RC = Round Compact, S = Sector, BR = IEC228 (BS6360) Round, BS\* = IEC228 (BS6360) Sector  
\* = Pre-rounding required, consult Cembre for appropriate die set

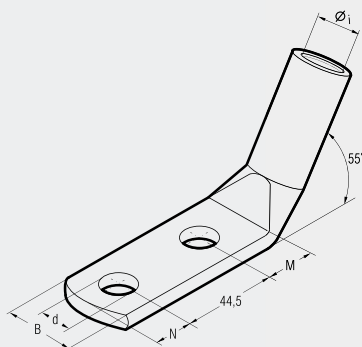

## 2A-2M/55°

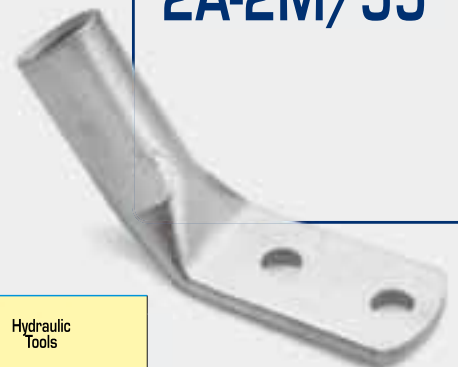

Conductor Size (sqmm) & Format	Ø Stud mm	Ref.	Dimensions mm					Quantity Box/Bag	Hydraulic Tools
			Øi	B	M	N	d		
400 R	14	2 A 80 - 2 M 14/55°	27,0	51,0	22	16	15	10/5	HT 120 and tools and heads with 130 kN crimping force ECW-H3D RHU 520
600 R ÷ 630 R	14	2 A 120 - 2 M 14/55°	33,4	61,5	22	16	15	15/3	

Conductor Format: R = Round

The 2A-2M/55° Copper Tube Terminal Lugs have the same characteristics as the CA-2M and 2A-2M ranges, with the additional feature of the palm bent at 55°.