

MECHANICAL FIXING LUGS

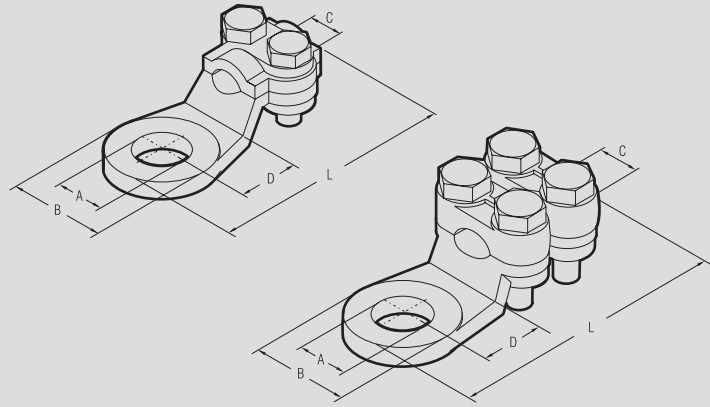

Material:
Brass OT 58 UNI 5705
nickel-plated.
Zinc plated steel bolts.

2 bolt fixing lugs Ø A standard

Conductor Size sqmm	Ref.	A bolt	Dimensions mm				Quantity
			B	C	D	L	
16	2155	M8	18,0	4,5	12,5	40	100
25	2156	M8	19,5	6,0	13,0	43	100
35	2157	M12	23,0	7,0	15,0	49	50

4 bolt fixing lugs Ø A standard

Conductor Size sqmm	Ref.	A bolt	Dimensions mm				Quantity
			B	C	D	L	
50	2158	M12	23,5	8	16,0	57	50
75	2160	M12	28,0	10	20,0	65	25
100	2161	M12	31,0	13	17,0	66	25
125	2162	M15	33,0	14	18,0	71	25
150	2163	M14	34,0	16	19,5	75	25
175	2164	M15	36,0	16	21,0	78	25
200	2165	M16	38,5	18	23,0	84	10
300	2167	M20	46,0	23	28,0	103	5

2 bolt fixing lugs Ø A large

Conductor Size sqmm	Ref.	A bolt	Dimensions mm				Quantity
			B	C	D	L	
16	2171	M10	18,0	4,5	12,5	40	100
25	2172	M10	19,5	6,0	13,0	43	100
35	2173	M14	23,0	7,0	15,0	49	50
50	2174	M14	25,0	8,0	17,0	56	50

4 bolt fixing lugs Ø A large

Conductor Size sqmm	Ref.	A bolt	Dimensions mm				Quantity
			B	C	D	L	
75	2176	M16	28	10	20	65	25